

# Clarke®



## 12V/24V INTELLIGENT BATTERY CHARGER/MAINTAINER

MODEL NO: IBC12/24

PART NO: 6267016

## OPERATION & MAINTENANCE INSTRUCTIONS



ORIGINAL INSTRUCTIONS

DL1123

---

## INTRODUCTION

---

Thank you for purchasing this CLARKE Battery Charger/Maintainer.

Please read this manual thoroughly, before attempting to operate this product and carefully follow all instructions given. It is vitally important that all precautions are taken, as specified, which will not only provide protection for yourself and that of others around you, but will also ensure that the battery charger will give you long and satisfactory service.

---

## GUARANTEE

---







This CLARKE product is guaranteed against faulty manufacture for a period of 12 months from the date of purchase. Please keep your receipt as proof of purchase. This guarantee is invalid if the product is found to have been abused or tampered with in any way, or not used for the purpose for which it was intended. Faulty goods should be returned to their place of purchase, no product can be returned to us without prior permission.

This guarantee does not effect your statutory rights.

---

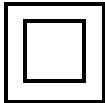
## SAFETY SYMBOLS

---

	Before Use, Read The Instructions Fully		For Indoor Use Only
	Class II Appliance		Wear Eye Protection
	Wear a Protective Mask		Wear Protective Gloves
	Warning: Explosive gases, prevent flames, sparks and use in well ventilated area		

---

# SAFETY PRECAUTIONS

---



**WARNING: ALWAYS SWITCH OFF THE CHARGER WHEN CONNECTING OR DISCONNECTING LEADS TO AVOID SPARKING AS HIGHLY INFLAMMABLE HYDROGEN GAS CAN BE RELEASED IN THE PROCESS OF BATTERY CHARGING**

---

## PLEASE READ BEFORE USING THIS UNIT

1. Batteries can generate explosive gases during normal operation. **ALWAYS** use in well ventilated area.
2. **DO NOT** smoke, strike a match or cause a spark in the vicinity of the battery or engine. **AVOID** explosive gas, flames and sparks.
3. Remove all personal jewellery, such as rings, bracelets, necklaces and watches while working with a vehicle battery. These items may produce a short circuit and could cause severe burns.
4. Be extra cautious to reduce the risk of dropping a metal tool onto the battery. It may spark or short circuit the battery or other electrical hardware which may cause an explosion or fire.
5. **ALWAYS** wear complete eye, hand and clothing protection. **AVOID** touching eyes while working near a battery.
6. Study all battery manufacturers specific precautions, such as removing or not removing cell caps while charging and recommended rates of charge.
7. Clean battery terminals before connection with the charger. Be careful to keep corrosion from coming in to contact with eyes.
8. When it is necessary to remove the battery from the vehicle to charge, always remove grounded terminal from the battery first. Make sure all accessories in the vehicle are switched off in order to prevent an arc.
9. This charger is **NOT** intended to supply power to an extra low voltage electrical system or to charge dry cell batteries. Charging dry cell batteries may cause the battery to burst and cause injury to person or property.
10. **NEVER** charge a frozen, damaged, leaking or non rechargeable battery.
11. If battery electrolyte contacts skin or clothing, wash immediately with soap and water. If electrolyte enters your eye, immediately flood eye with running clean cold water for at least 15 minutes and seek medical attention immediately.
12. **DO NOT** place the charger in the engine compartment, near moving parts or near the battery. Place as far away from them as the cable permits.

13. **NEVER** place the charger directly above the battery being charged, gases or fluids from the battery will corrode and/or damage the charger.
14. **DO NOT** cover the charger while charging.
15. **DO NOT** expose to rain or wet conditions.
16. Connect and disconnect the DC output connections only after disconnecting the charger from the mains power supply.
17. Use of an attachment not recommended or sold by the manufacturer may result in a risk of fire, electric shock or injury to persons.
18. **DO NOT** overcharge batteries by selecting the wrong charge mode.
19. To reduce the risk of damage to the electric plug and cord, pull by the plug rather than the cord when disconnecting charger from mains power supply.
20. To reduce risk of electric shock, unplug charger from mains power supply before attempting any maintenance or cleaning.
21. Operate with caution if the charger has received a direct hit of force or been dropped. Have it checked and repaired if damaged.
22. **NEVER** attempt any repairs yourself. If you have a problem with your charger contact your local CLARKE dealer or contact [service@clarkeinternational.com](mailto:service@clarkeinternational.com)
23. When charging is complete, ensure that the vehicle battery leads are secured to the proper terminals which should be clean, and lightly smeared with petroleum jelly to prevent corrosion. Finally, re-check the electrolyte level.

# ELECTRICAL CONNECTIONS



**WARNING! READ THESE ELECTRICAL SAFETY INSTRUCTIONS THOROUGHLY BEFORE CONNECTING THE PRODUCT TO THE MAINS SUPPLY.**

Before switching the product on, make sure that the voltage of your electricity supply is the same as that indicated on the rating plate. This product is designed to operate on 230V AC 50Hz. Connecting it to any other power source may cause damage.

This product may be fitted with a non-rewireable plug. If it is necessary to change the fuse in the plug, the fuse cover must be refitted. If the fuse cover becomes lost or damaged, the plug must not be used until a suitable replacement is obtained.

If the plug has to be changed because it is not suitable for your socket, or due to damage, it should be cut off and a replacement fitted, following the wiring instructions shown below. The old plug must be disposed of safely, as insertion into a mains socket could cause an electrical hazard.

If the colours of the wires in the power cable of this product do not correspond with the markings on the terminals of your plug, proceed as follows.

- The **Blue** wire must be connected to the terminal marked **N** or coloured **Black**.
- The **Brown** wire must be connected to the terminal marked **L** or coloured **Red**.

**Plug must be BS1363/A approved.**

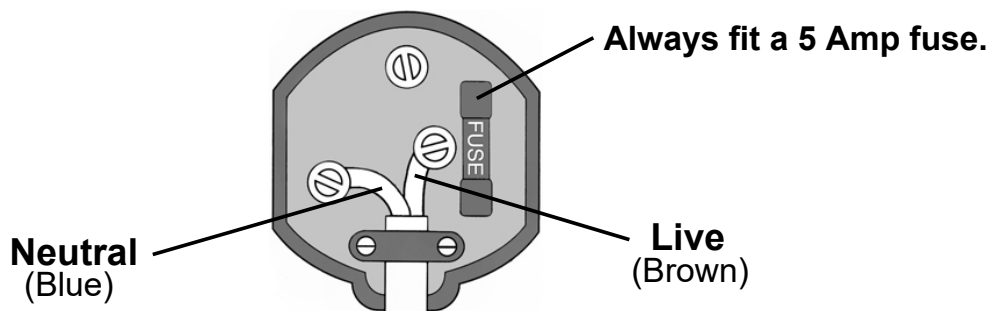

**Ensure that the outer sheath of the cable is firmly held by the clamp**

**We strongly recommend that this machine is connected to the mains supply via a Residual Current Device (RCD)**

If in any doubt, consult a qualified electrician. **DO NOT** attempt any repairs yourself.



**This symbol indicates that this is a Class II product, and does not require an earth connection.**

# OVERVIEW



1	Battery Charger Unit	7	Charging Clamp/Lead Negative (Black)
2	Display/Mode Buttons	8	Charging Clamp/Lead 40A Fuse
3	LCD Display	9	Charging Ring Terminal Positive (Red)
4	Power Cable with 5A Plug	10	Charging Ring Terminal Negative (Black)
5	Charging Cable	11	Wall Mounting Holes
6	Charging Clamp/Lead Positive (Red)	12	1 x Spare 40A Fuse (Not Shown)

**NOTE:** The charger comes with crocodile clamps for clamping onto the battery terminals and vehicle bodywork, and ring terminal connectors for direct connection to the battery terminals. These can be changed depending on the type of vehicle battery and terminals under charge.

# DISPLAY INDICATORS

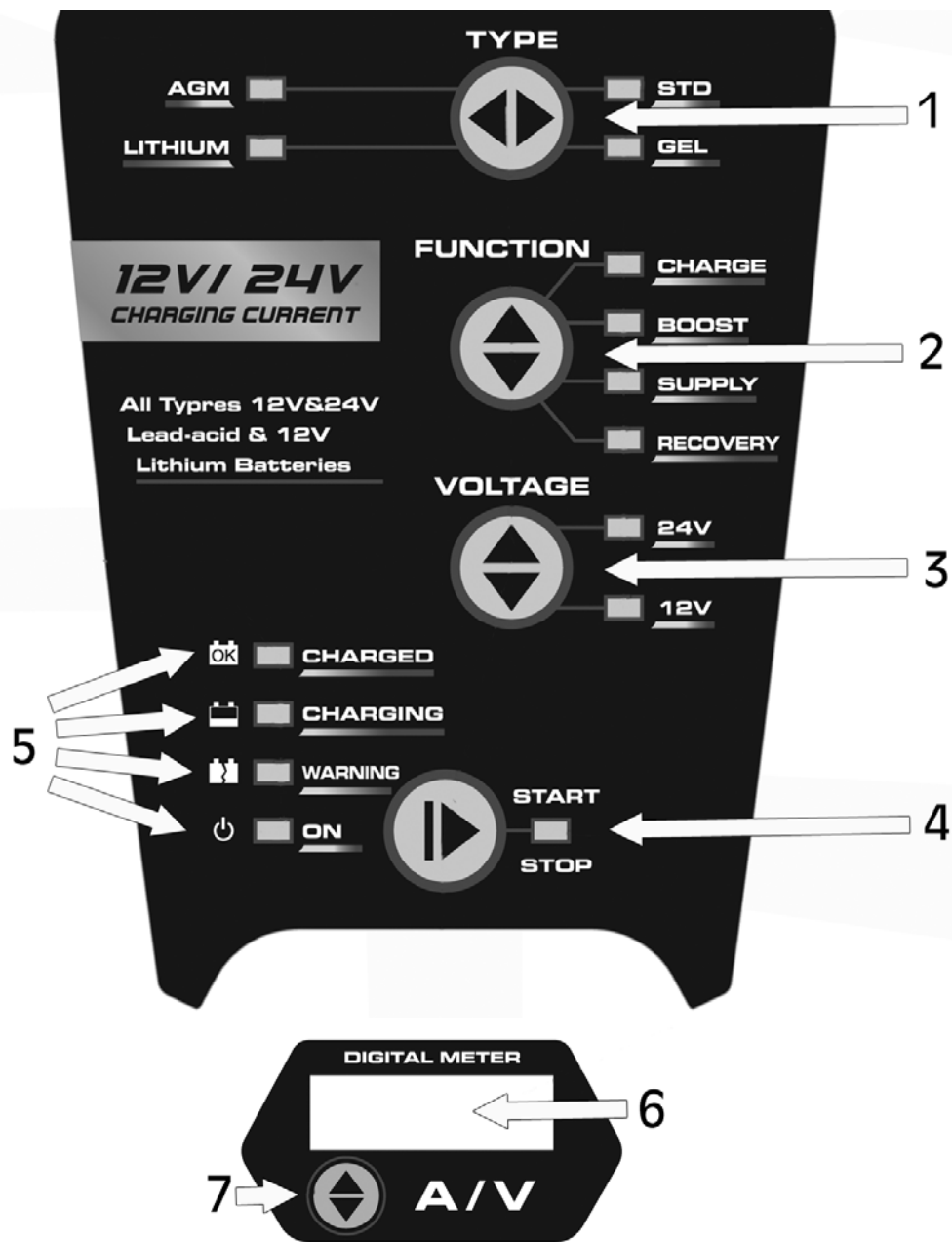

1	Battery Type Button: Choose between AGM, STD, GEL Lithium-ion(BMS) or 4 Cell LiFePO4	5	Display Lights: Showing Charged, Charging, Warning & Power On.
2	Function Button: Choose between Charge, Boost, Supply or Recovery	6	LCD Display Screen
3	Voltage Button: Choose between 12V or 24V	7	Display Button: Choose between showing the ampage and voltage of the battery on charge
4	Stop/Start Button		

---

## PREPARATION

---

1. It may be necessary to remove the battery from a vehicle to charge it.
  - Always remove the grounded terminal from the battery first.
  - Ensure all accessories in the vehicle are switched off to prevent sparking.
2. Clean the battery terminals. Be careful to keep any corrosive matter from coming in contact with eyes. If corrosive matter enters your eye, immediately flood eye with running clean cold water for at least 15 minutes and seek medical attention immediately.
3. If the battery can be topped up, add distilled water to each cell until the battery acid reaches the level specified by the battery manufacturer. This helps remove unwanted gas from the cell. **DO NOT** overfill. For a battery without cell caps, follow the manufacturer's instructions.
4. Study all the battery manufacturer's specified precautions: for example, removing or not removing cell caps while being charged and recommended rates of charge.
5. Refer to the vehicle manual and battery rating plate to find the voltage of the battery and make sure that the output is set to the correct voltage.
6. If the charger has adjustable charge rate, charge the battery initially at the lowest rate.

## CHARGER LOCATION

1. The charger can be wall or bench mounted, via the 4 mounting holes (2 top and 2 bottom of the main body of the charger).
2. The charger comes with interchangeable charging leads. Type 1 are crocodile clamps for connection to standard battery terminals and vehicle bodywork. Type 2 are ring terminals for connection to screw type battery terminals.
3. Place the charger as far away from the battery as possible.
4. **DO NOT** position the charger above the battery during the charging procedure. Gases from the battery may corrode and damage the charger.
5. **DO NOT** let battery acid drip on the charger when reading a hydrometer for specific gravity or when you fill the battery.
6. **DO NOT** use the charger in an enclosed space with reduced airflow.



## ABOUT THE IBC 12/24

1. The IBC12/24 is designed for charging 12V/24V lead-acid and 12V Lithium-ion(BMS) & 4 Cell LiFePO4 batteries.
2. It has a built-in intelligent microprocessor that makes charging faster, easier and safer.
3. This charger has safety features including spark proof, protection for reverse polarity, short circuit, overcurrent, overcharge and overheating.
4. When starting, the battery voltage type is 12V by default. The user can select the battery voltage type by pressing the "VOLTAGE" button in standby.
5. When starting, the charger is set to work for STD battery type by default. The user can select the battery type including STD, GEL, AGM or Lithium-ion(BMS) & LiFePO4 (12V battery only) by pressing and holding the "TYPE" button in standby.
6. When the charger is powered ON, it enters the standby mode by default. The user can select the functions including CHARGE, SUPPLY, RECOVERY or BOOST by pressing the "FUNCTION" button in standby followed by pressing the "START/STOP" button to start the charging.
7. The user can check the charge current or the battery voltage by pressing the "DISPLAY" button below the LCD display.
8. When the battery level indicator turns to 100% (solid CHARGED LED), it will automatically switch from full charge to maintenance status to maintain the battery during prolonged periods of storage without overcharging or damaging the battery.
9. A marine (boat) battery **MUST BE** removed and charged on shore. To charge it onboard requires equipment specially designed for marine use.

---

# CHARGING

---

## CHARGING MODES

The IBC12/24 has 11 modes: STANDBY, 12V STD, 12V GEL, 12V AGM, 12V Lithium-ion(BMS)/4 Cell LiFePO4, 24V STD, 24V GEL, 24V AGM, RECOVERY, 13.6V SUPPLY and 12V BOOST. For some charge modes, the mode button must be held for three (3) seconds and/or pressed to enter the mode.

**WARNING: DO NOT OPERATE THE CHARGER UNTIL YOU CONFIRM THE APPROPRIATE CHARGE MODE FOR YOUR BATTERY.**

Mode	Battery Size (Ah)	Explanation
STANDBY	N/A	Not charging or providing any power
12V STD	50-400	Charging 12V STD battery
12V GEL	50-400	Charging 12V GEL battery
12V AGM	50-400	Charging 12V battery below 10°C (50°F) or 12V AGM battery
12V LITHIUM	50-400	Charging 12V Lithium-ion(BMS)/4 Cell LiFePO4 battery only
24V STD	50-200	Charging 24V STD battery
24V GEL	50-200	Charging 24V GEL battery
24V AGM	50-200	Charging 24V battery below 10°C (50°F) or 24V AGM battery
RECOVERY	50-400	An advanced battery recovery mode for repairing old, idle, stratified or sulfated battery
13.6V (10A) SUPPLY	N/A	Converting to a DC power supply for powering 12V DC devices or as a memory retainer when replacing a battery
12V BOOST	50-400	Delivering 20A for five (5) minutes to jump charge the battery

**WARNING: THESE “HOLD AND/OR PRESS” MODES ARE ADVANCED CHARGING MODES THAT REQUIRE YOUR FULL ATTENTION BEFORE SELECTING.**

### USING 12V LITHIUM-ION(BMS)/4 CELL LIFEPO4

This mode is designed for 12V Lithium-ion(BMS)/ 4 Cell LiFePO4 batteries only. Some Lithium-iron batteries may be unstable and unsuitable for charging. Consult the battery manufacturer before charging and ask for the recommended charging voltage and current.

## USING RECOVERY (12V ONLY)

This mode is for LEAD-ACID batteries only. It is an advanced battery recovery mode for repairing old, idle, stratified or sulfated batteries. Not all batteries can be recovered. For optimal results, take the battery through a full charge cycle, bringing the battery to full charge before using this mode. One RECOVERY cycle can take up to eight (8) hours to complete the recovery process and will enter STANDBY mode when completed. This mode uses a high charging voltage and may cause some water loss in WET cell batteries. Plus, some batteries and electronics may be sensitive to high charging voltage. To minimise risks, disconnect the battery from the vehicle before using this mode.

## USING 13.6V SUPPLY

This mode converts the charger to a constant voltage, constant current DC power supply. It can be used to power 12V DC devices. Prior to use, read your 12V DC device manual to determine if it is suitable for use with this mode. As a power supply, it can also be used to retain a vehicle's on-board computer settings during a battery repair or replacement. 13.6V supply mode provides 13.6V at 10A (Max). Both spark proof and reverse polarity protection modes are disabled in this mode. **DO NOT** allow the positive and negative battery clamps to touch or connect to each other as the charger could generate sparks.

## USING 12V BOOST

BOOST mode is an advanced mode that requires your full attention before selecting. To operate BOOST, the charger must be connected to a 12V lead-acid battery with the battery clamps connected. For optimal results, allow BOOST to complete its five (5) minute charge. After the 5 minute boost, the LCD display will show "COOLING", and you are ready to start your vehicle (whether the battery charged indicator is lit or not). After each boost, the charger has a mandatory five (5) minute cool down for safety reasons (even if you press the BOOST button again, the charger will not work). After cooling, the charger will enter STANDBY mode. If unsuccessful when starting your vehicle, let the battery rest for 15 minutes and try the BOOST again. Most vehicles will start with one (1) boost. **DO NOT** use the BOOST mode more than two (2) times within a 24 hour period. If two (2) boosts cannot successfully start your vehicle, have your battery replaced or evaluated by a local battery retailer.

## CONNECTING TO THE BATTERY

1. Identify the polarity of the battery terminals. The positive battery terminal is typically red and/or marked by the letters or symbols: POS, P, +. The negative battery terminal is typically black or blue and/or marked by the letters or symbols: NEG, N, -.
2. **DO NOT** make any connections to the carburetor, fuel lines or thin metal parts.

3. Identify if you have a negative or positive grounded vehicle. This can be done by identifying which battery terminal (NEG or POS) is connected to the chassis. If unsure, consult the vehicle handbook.
4. For a negative grounded vehicle (most common): connect the RED POSITIVE clamp first to the positive battery terminal, then connect the BLACK NEGATIVE clamp to the negative battery terminal or vehicle chassis.
5. For a positive grounded vehicle: connect the BLACK NEGATIVE clamp first to the negative battery terminal, then connect the RED POSITIVE clamp to the positive battery terminal or vehicle chassis.
6. Run the required charging mode.

## **FINISHING CHARGING THE BATTERY**

1. Disconnect the charger from the mains power supply.
2. Disconnect the black charging cable from the bodywork.
3. Disconnect the red charging cable from the positive pole of the battery.

**NOTE: IMPORTANT,** In case of positive earthing, first disconnect the red charging cable from the bodywork and then the black charging cable from the battery.

4. Screw or push the battery stoppers back into position (if there are any).

**NOTE:** If the mains power supply is disconnected but the charger cables are still connected to the battery, the charger will draw off a small amount of electricity from the battery. We therefore recommend that you always completely remove the charger from the battery when not in use.

5. Wind up the leads when finished, using the clamp tidies on the side of the charger.

## CHARGING STEPS

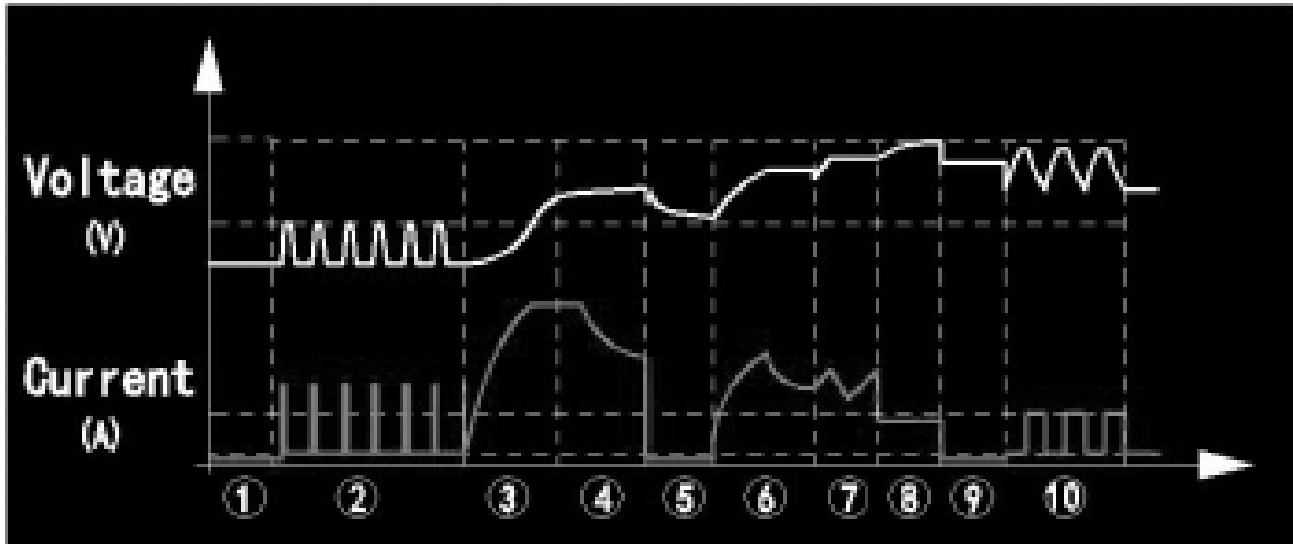

- STEP 1: Analysing 1 (Checks if battery has connected with the charger).
- STEP 2: Desulphation (Pulsing charging to remove sulphates).
- STEP 3: Soft Start (Charges with gradually increasing charging current).
- STEP 4: Controlled Current Charge (Adjusts the charging current intelligently).
- STEP 5: Analysing 2 (Tests if the battery can absorb charge).
- STEP 6: Constant Output Charge (Charges with constant voltage and compensates fake full charge caused by high current charging).
- STEP 7: Recovery Cycle Charge (Absorbs more charge and compensates side effect of reduced charging current).
- STEP 8: Absorption (Charges with constant trickle current for maximum battery voltage).
- STEP 9: Analysing 3 (Tests if the battery can hold charge).
- STEP 10: Maintenance (Continuously monitors the battery, and charges with trickle current once the voltage is lower than the threshold).

---

## CARE & MAINTANENCE

---

This battery charger requires minimal maintenance. As with any appliance or tool, a few common sense rules will prolong its working life.



**WARNING: ALWAYS BE SURE THE CHARGER IS UNPLUGGED BEFORE PERFORMING ANY MAINTENANCE OR CLEANING. ANY REPAIRS MUST BE DONE BY A QUALIFIED SERVICE TECHNICIAN.**

---

1. **ALWAYS** disconnect the charger from the main power supply when not in use.
  2. Wind up the leads when not in use, using the clamp tidies on the side of the charger. Examine the leads at regular intervals for damage and have them replaced if necessary.
  3. Clean the case and leads if necessary with a moist cloth and clean any corrosion from the clamps with a solution of water and baking soda.
- 

## ENVIRONMENTAL RECYCLING POLICY

---



Through purchase of this product, the customer is taking on the obligation to deal with the WEEE in accordance with the WEEE regulations in relation to the treatment, recycling & recovery and environmentally sound disposal of the WEEE.



In effect, this means that this product must not be disposed of with general household waste. It must be disposed of according to the laws governing Waste Electrical and Electronic Equipment (WEEE) at a recognised disposal facility.

## TROUBLESHOOTING ERROR DISPLAYS

LCD Display	Cause	Solution
ERROR + OVERHEAT	The charger is overheating	The charging will automatically pause. <b>DO NOT</b> cut off the power supply, and the charger will work again when it has cooled down.
ERROR + NO CONNECTION	Open circuit	Connect the red and black clamps to the battery terminals
	Dirty battery terminals	Clean the battery terminals
	Dead battery	Replace the battery with a new one immediately
	Output short circuit	Disconnect the red and black output terminals
ERROR + BATT TYPE	Charging in 12V mode for 24V battery	Restart the charger and choose the correct charge mode
ERROR + BAD BATTERY	Battery cannot store electric or cannot be recovered through RECOVERY mode	Replace the battery with a new one
		If RECOVERY mode has not be tried, try it for recovery
ERROR + REVERSE	Reverse Polarity	Exchange the red and black clamps to the correct battery terminals
ERROR + OVERLOAD	Overload in SUPPLY mode (will automatically shut down for 30 seconds as protection)	Disconnect the external device

# PARTS DIAGRAM

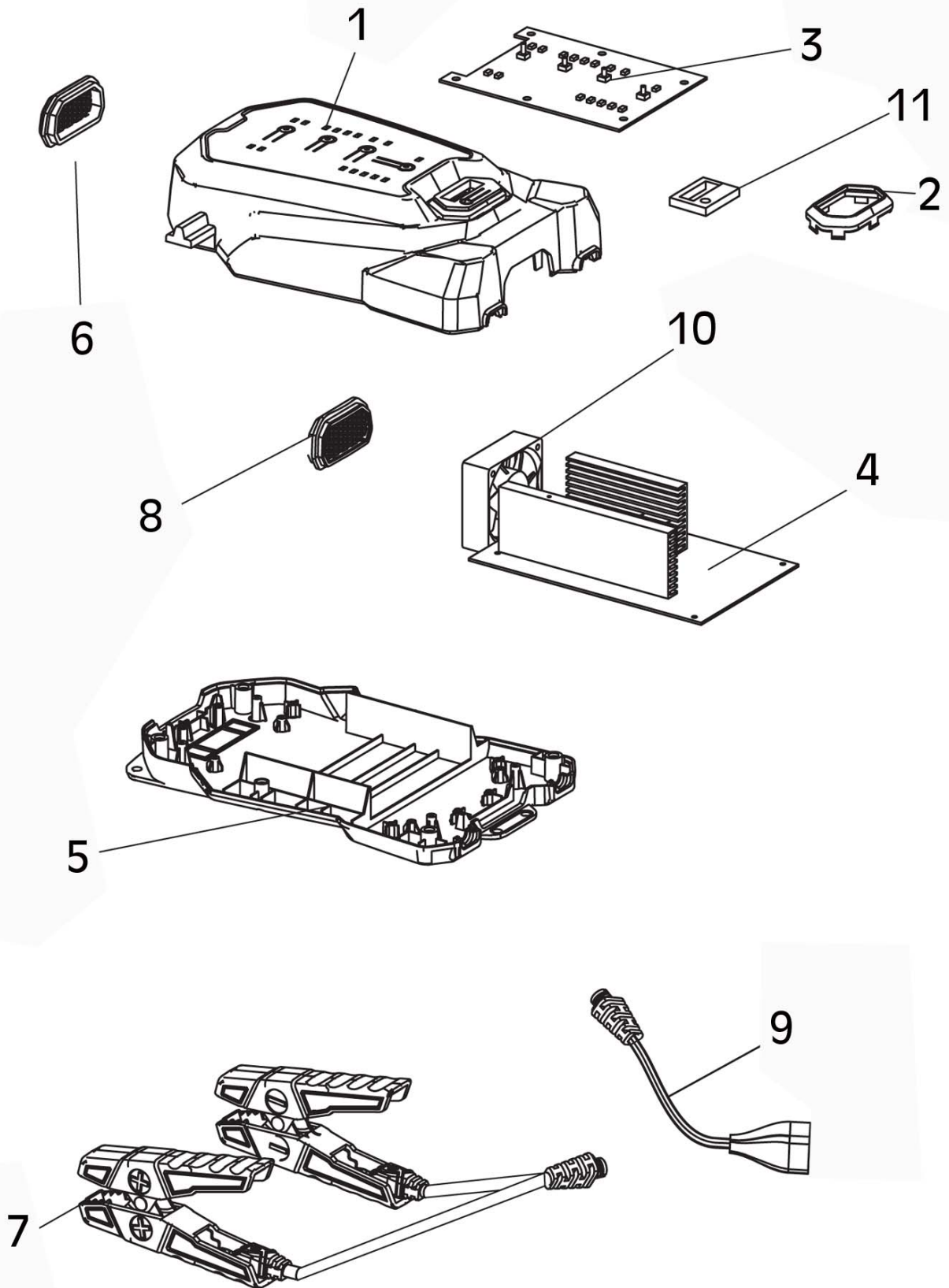



## PARTS LIST

No	DESCRIPTION	No	DESCRIPTION
1	Charger Front Cover	7	Charging Clamp Cable
2	LCD Display Cover	8	Charger Lower Vent Cover
3	Control - Printed Circuit Board	9	Power Cable
4	Function Panel	10	Fan
5	Charger Back Cover	11	LCD Display
6	Charger Upper Vent Cover	12	Charging Ring Cable (Not Shown)

## SPECIFICATIONS

Model Number	IBC12/24
Input Voltage / Current	230 V, 50Hz, 3.5A
Battery Charging Voltages:	12V & 24V
Compatible Battery Types	Lead Acid, WET, MF, EFB, GEL, AGM Lithium-ion(BMS)/4 Cell LiFePO4 (12V Only)
Start Voltage	>1V
Max. Input Power (12V/24V/Boost)	250W/265W/400W
Max. Input Current (12V/24V/Boost)	1.9A/2A/3A
Max. Output Power (12V/24V)	210W/225W
Max. Output Charging (12V/24V/Boost)	15A/8A/20A
Working Modes	Charge, Recovery, Boost & Supply
Charging Steps	10 steps
Charging Battery Size	12V: 50Ah up to 400Ah 24V: 50Ah up to 200Ah
IP Rating	IP20
Protection Class	Class II
Operating Temperature Range	0°C to 35°C
Dimensions (H x W x D)	75mm x 300mm x 200mm
Power Cable Length	1.8m
Charging Cable Lengths	Clamp Terminals: 640mm (inc. Clips) Ring Terminals: 540mm
Weight	2kg

# DECLARATION OF CONFORMITY - UKCA



Hemnall Street, Epping, Essex, CM16 4LG

## DECLARATION OF CONFORMITY

This is an important document and should be retained.

We hereby declare that this product(s) complies with the following legislation:

*The Electromagnetic Compatibility Regulations 2016*

*The Electrical Equipment (Safety) Regulations 2016*

*The Restriction of the Use of Certain Hazardous Substances in Electrical and Electronic Equipment Regulations 2012*

The following standards have been applied to the product(s):

*EN 60335-1:2012+A11+A13+A1+A14+A2+A15, EN 60335-2-29:2004+A2+A11, IEC 62321-7-1:2015, IEC 62321-4:2013+AMD1:2017, EN IEC 61000-3-2:2019+A1, EN IEC 55014-1:2021, EN 62233:2008, EN 61000-3-3:2013+A1+A2, EN IEC 55014-2:2021, IEC 62321-7-2:2017, IEC 62321-3-1:2013, IEC 62321-1:2013, IEC 62321-2:2013, IEC 62321-5:2013, IEC 62321-6:2015, IEC 62321-8:2017, ISO 17075-1:2017*

The technical documentation required to demonstrate that the product(s) meet(s) the requirement(s) of the aforementioned legislation has been compiled and is available for inspection by the relevant enforcement authorities.

The UKCA mark was first applied in: 2023

**Product Description:** Battery Charger  
**Model Number(s):** IBC 12/24  
**Serial/Batch Number:** Refer to product/packaging label  
**Date of Issue:** 06/11/2023

**Signed:**

J.A Clarke

Director

# DECLARATION OF CONFORMITY - CE



**Clarke**<sup>®</sup>  
**INTERNATIONAL**

Fitzwilliam Hall, Fitzwilliam Place, Dublin 2

## DECLARATION OF CONFORMITY

This is an important document and should be retained.

We hereby declare that this product(s) complies with the following legislation:

2014/30/EU                      *Electromagnetic Compatibility Directive*  
2014/35/EU                      *Low Voltage Directive*  
2011/65/EU                      *Restriction of Hazardous Substances (RoHS) Directive*

The following standards have been applied to the product(s):

*EN 60335-1:2012+A11+A13+A14+A2+A15, EN 60335-2-29:2004+A2+A11, IEC 62321-7-1:2015,  
IEC 62321-4:2013+AMD1:2017, EN IEC 61000-3-2:2019+A1, EN IEC 55014-1:2021, EN 62233:2008,  
EN 61000-3-3:2013+A1+A2, EN IEC 55014-2:2021, IEC 62321-7-2:2017, IEC 62321-3-1:2013,  
IEC 62321-1:2013, IEC 62321-2:2013, IEC 62321-5:2013, IEC 62321-6:2015, IEC 62321-8:2017,  
ISO 17075-1:2017*

The technical documentation required to demonstrate that the product(s) meet(s) the requirement(s) of the aforementioned legislation has been compiled and is available for inspection by the relevant enforcement authorities.

The CE mark was first applied in: 2023

**Product Description:**                      Battery Charger  
**Model Number(s):**                      IBC 12/24  
**Serial/Batch Number:**                      Refer to product/packageing label  
**Date of Issue:**                      06/11/2023

**Signed:**

J.A Clarke

Director

# A SELECTION FROM THE VAST RANGE OF

# Clarke®

## QUALITY PRODUCTS



**AIR COMPRESSORS**  
From DIY to industrial, Plus air tools, spray guns and accessories.

**GENERATORS**  
Prime duty or emergency standby for business, home and leisure.

**POWER WASHERS**  
Hot and cold, electric and engine driven - we have what you need

**WELDERS**

Mig, Arc, Tig and Spot.  
From DIY to auto/industrial.

**METALWORKING**  
Drills, grinders and saws for DIY and professional use.

**WOODWORKING**  
Saws, sanders, lathes, mortisers and dust extraction.

**HYDRAULICS**  
Cranes, body repair kits, transmission jacks for all types of workshop use.

**WATER PUMPS**  
Submersible, electric and engine driven for DIY, agriculture and industry.

**POWERTOOLS**  
Angle grinders, cordless drill sets, saws and sanders.

**STARTERS/CHARGERS**  
All sizes for car and commercial use.



## PARTS & SERVICE: 0208 988 7400

**Parts Enquiries**  
[Parts@clarkeinternational.com](mailto:Parts@clarkeinternational.com)

**Servicing & Technical Enquiries**  
[Service@clarkeinternational.com](mailto:Service@clarkeinternational.com)

SALES: UK 01992 565333 or Export 00 44 (0)1992 565335

**Clarke® INTERNATIONAL** Hemnall Street, Epping, Essex CM16 4LG  
[www.clarkeinternational.com](http://www.clarkeinternational.com)